

## FEATURES

- Holds microprocessor in check during power transients
- Halts and restarts an out-of-control microprocessor
- Warns microprocessor of an impending power failure
- Converts CMOS SRAM into nonvolatile memory
- Unconditionally write protects memory when power supply is out of tolerance
- Delays write protection until completion of the current memory cycle
- Consumes less than 200 nA of battery current
- Controls external power switch for high current applications
- Debounces pushbutton reset
- Accurate 10% power supply monitoring
- Optional 5% power supply monitoring designated DS1238A-5
- Provides orderly shutdown in microprocessor applications
- Pin-for-pin compatible with MAX691
- Standard 16-pin DIP or space-saving 16-pin SOIC
- Optional industrial temperature range -40°C to +85°C

## PIN ASSIGNMENT

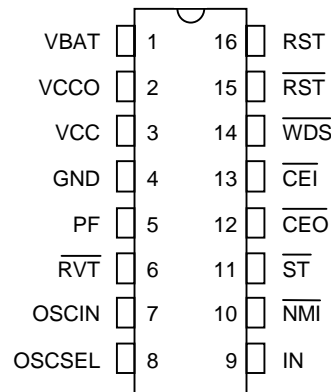

16-Pin DIP (300-mil)  
See Mech. Drawings Section

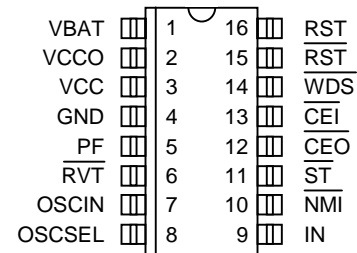

16-Pin SOIC (300-mil)  
See Mech. Drawings Section

## PIN DESCRIPTION

V <sub>BAT</sub>	- +3-Volt Battery Input
V <sub>CCO</sub>	- Switched SRAM Supply Output
V <sub>CC</sub>	- +5-Volt Power Supply Input
GND	- Ground
PF	- Power-Fail
$\overline{\text{RVT}}$	- Reset Voltage Threshold
OSCIN	- Oscillator In
OSCSEL	- Oscillator Select
IN	- Early Warning Input
$\overline{\text{NMI}}$	- Non-Maskable Interrupt
$\overline{\text{ST}}$	- Strobe Input
$\overline{\text{CEO}}$	- Chip Enable Output
$\overline{\text{CEI}}$	- Chip Enable Input
$\overline{\text{WDS}}$	- Watchdog Status
$\overline{\text{RST}}$	- Reset Output (active low)
RST	- Reset Output (active high)

## DESCRIPTION

The DS1238A MicroManager provides all the necessary functions for power supply monitoring, reset control, and memory backup in microprocessor-based systems. A precise internal voltage reference and comparator circuit monitor power supply status. When an out-of-tolerance condition occurs, the microprocessor reset and power-fail outputs are forced active, and static RAM control unconditionally write protects external memory. The DS1238A also provides early warning detection of a user-defined threshold by driving a non-maskable interrupt. External reset control is provided by a pushbutton reset

debounce circuit connected to the  $\overline{\text{RST}}$  pin. An internal watchdog timer can also force the reset outputs to the active state if the strobe input is not driven low prior to watchdog timeout. Oscillator control pins OSCSEL and OSCIN provide either external or internal clock timing for both the reset pulse width and the watchdog timeout period. The Watchdog Status and Reset Voltage Threshold are provided via  $\overline{\text{WDS}}$  and  $\overline{\text{RVT}}$ , respectively. A block diagram of the DS1238A is shown in NO TAG.

## PIN DESCRIPTION

PIN NAME	DESCRIPTION
$V_{\text{BAT}}$	+3V battery input provides nonvolatile operation of control functions.
$V_{\text{CCO}}$	$V_{\text{CC}}$ output for nonvolatile SRAM applications.
$V_{\text{CC}}$	+5V primary power input.
PF	Power-fail indicator, active high, used for external power switching as shown in NO TAG.
$\overline{\text{RVT}}$	Reset Voltage Threshold. Indicates that $V_{\text{CC}}$ is below the reset voltage threshold.
OSCIN	Oscillator input or timing capacitor. See NO TAG.
OSCSEL	Oscillator Select. Selects internal or external clock functions. See NO TAG.
IN	Early warning power-fail input. This voltage sense point can be tied (via resistor divider) to a user-selected voltage.
$\overline{\text{NMI}}$	Non-maskable interrupt. Used in conjunction with the IN pin to indicate an impending power failure.
$\overline{\text{ST}}$	Strobe input. A high-to-low transition will reset the watchdog timer, indicating that software is still in control.
$\overline{\text{CEO}}$	Chip enable output. Used with nonvolatile SRAM applications.
$\overline{\text{CEI}}$	Chip enable input.
$\overline{\text{WDS}}$	Watchdog Status. Indicates that a watchdog timeout has occurred.
$\overline{\text{RST}}$	Active low reset output.
RST	Active high reset output.

## POWER MONITOR

The DS1238A employs a bandgap voltage reference and a precision comparator to monitor the 5-volt supply ( $V_{\text{CC}}$ ) in microprocessor-based systems. When an out-of-tolerance condition occurs, the  $\overline{\text{RVT}}$ , RST, and  $\overline{\text{RST}}$  outputs are driven to the active state. The  $V_{\text{CC}}$  trip point ( $V_{\text{CCTP}}$ ) is set for 10% operation so that the  $\overline{\text{RVT}}$ , RST and  $\overline{\text{RST}}$  outputs will become active as  $V_{\text{CC}}$  falls below 4.5 volts (4.37 typical). The  $V_{\text{CCTP}}$  for the 5% operation option (DS1238A-5) is set for 4.75 volts (4.62 typical). The RST and  $\overline{\text{RST}}$  signals are excellent for microprocessor reset control, as processing is stopped at the last possible moment of in-tolerance  $V_{\text{CC}}$ . On power-up,  $\overline{\text{RVT}}$  will become inactive as soon as  $V_{\text{CC}}$  rises above  $V_{\text{CCTP}}$ . However, the RST and  $\overline{\text{RST}}$  signals remain active for a minimum of 50 ms (100 ms typical) after  $V_{\text{CCTP}}$  is reached to allow the power supply and microprocessor to stabilize.

## DS1238A FUNCTIONAL BLOCK DIAGRAM Figure 1

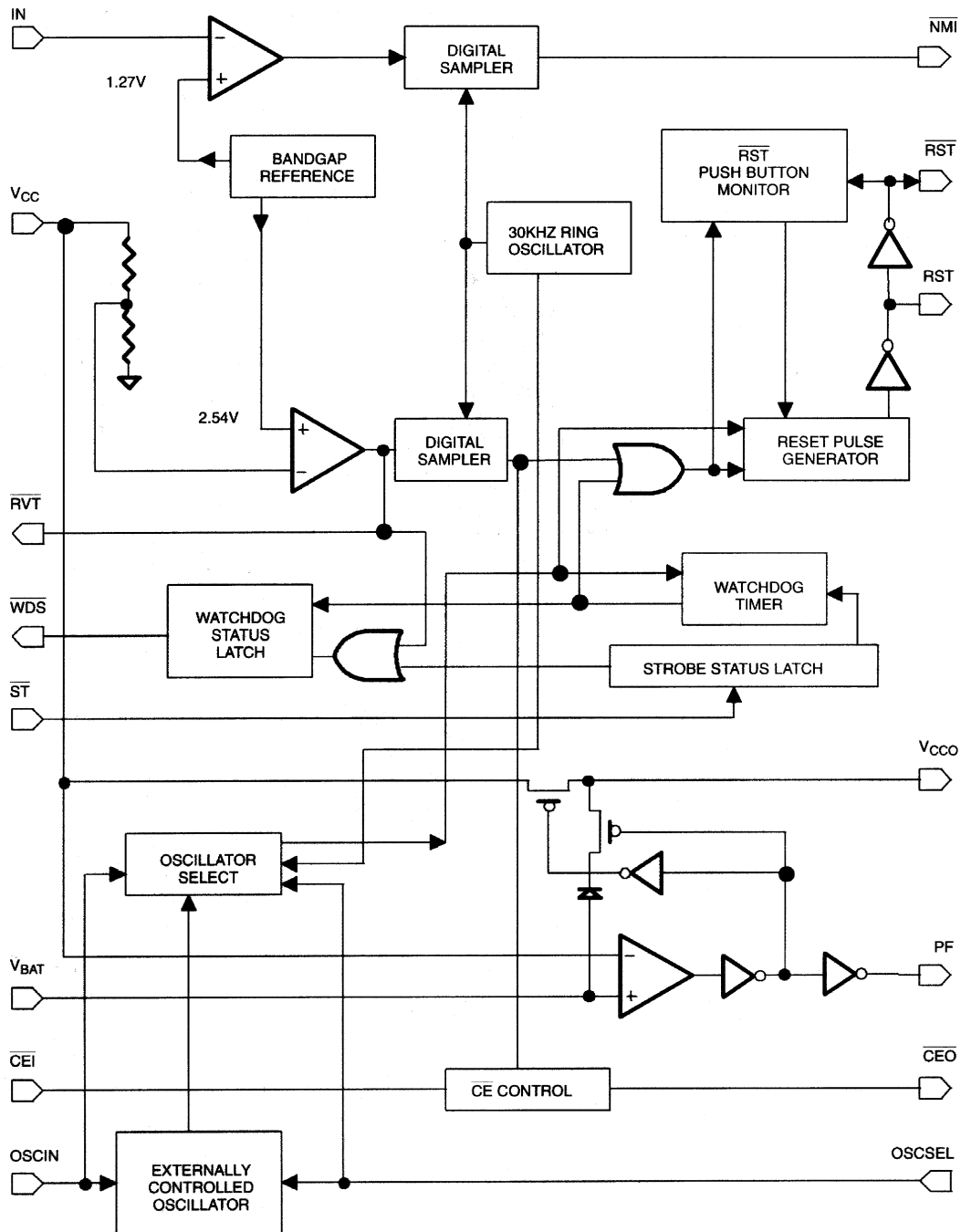

## WATCHDOG TIMER

The DS1238A provides a watchdog timer function which forces the  $\overline{WDS}$ ,  $\overline{RST}$ , and  $\overline{RST}$  signals to the active state when the strobe input ( $\overline{ST}$ ) is not stimulated for a predetermined time period. This time period is described below in NO TAG. The watchdog timeout period begins as soon as  $\overline{RST}$  and  $\overline{RST}$  are inactive. If a high-to-low transition occurs at the  $\overline{ST}$  input prior to timeout, the watchdog timer is reset and begins to timeout again. The  $\overline{ST}$  input timing is shown in NO TAG. In order to guarantee that the watchdog timer does not timeout, a high-to-low transition on  $\overline{ST}$  must occur at or less than the minimum timeout of the watchdog as described in the AC Electrical Characteristics. If the watchdog timer is allowed to time out, the  $\overline{WDS}$ ,  $\overline{RST}$ , and  $\overline{RST}$  outputs are driven to the active state.  $\overline{WDS}$  is a latched signal which indicates the watchdog status, and is activated as soon as the watchdog timer completes a

full period as outlined in NO TAG. The  $\overline{\text{WDS}}$  pin will remain low until one of three operations occurs. The first is to strobe the  $\overline{\text{ST}}$  pin with a falling edge, which will both set the  $\overline{\text{WDS}}$  as well as the watchdog timer count. The second is to leave the  $\overline{\text{ST}}$  pin open, which disables the watchdog. Lastly, the  $\overline{\text{WDS}}$  pin is active low whenever  $V_{CC}$  falls below  $V_{CCTP}$  and activates the  $\overline{\text{RVT}}$  signal. The  $\overline{\text{ST}}$  input can be derived from microprocessor address, data, or control signals, as well as microcontroller port pins. Under normal operating conditions, these signals would routinely reset the watchdog timer prior to timeout. The watchdog is disabled by leaving the  $\overline{\text{ST}}$  input open, or as soon as  $V_{CC}$  falls to  $V_{CCTP}$ .

## NON-MASKABLE INTERRUPT

The DS1238A generates a non-maskable interrupt ( $\overline{\text{NMI}}$ ) for early warning of a power failure to the microprocessor. A precision comparator monitors the voltage level at the IN pin relative to an on-chip reference generated by an internal band gap. The IN pin is a high-impedance input allowing for a user-defined sense point. An external resistor voltage divider network (NO TAG) is used to interface with high voltage signals. This sense point may be derived from the regulated 5-volt supply, or from a higher DC voltage level closer to the main system power input. Since the IN trip point  $V_{TP}$  is 1.27 volts, the proper values for R1 and R2 can be determined by the equation as shown in NO TAG. Proper operation of the DS1238A requires that the voltage at the IN pin be limited to  $V_{IH}$ . Therefore, the maximum allowable voltage at the supply being monitored ( $V_{MAX}$ ) can also be derived as shown in NO TAG. A simple approach to solving this equation is to select a value for R2 of high enough value to keep power consumption low, and solve for R1. The flexibility of the IN input pin allows for detection of power loss at the earliest point in a power supply system, maximizing the amount of time for microprocessor shutdown between  $\overline{\text{NMI}}$  and RST or  $\overline{\text{RST}}$ .

When the supply being monitored decays to the voltage sense point, the DS1238A will force the  $\overline{\text{NMI}}$  output to an active state. Noise is removed from the  $\overline{\text{NMI}}$  power-fail detection circuitry using built-in time domain hysteresis. That is, the monitored supply is sampled periodically at a rate determined by an internal ring oscillator running at approximately 30 kHz (33  $\mu\text{s}$ /cycle). Three consecutive samplings of out-of-tolerance supply (below  $V_{SENSE}$ ) must occur at the IN pin to active  $\overline{\text{NMI}}$ . Therefore, the supply must be below the voltage sense point for approximately 100  $\mu\text{s}$  or the comparator will reset. In this way, power supply noise is removed from the monitoring function preventing false trips. During a power-up, any IN pin levels below  $V_{TP}$  detected by the comparator are disabled from reaching the  $\overline{\text{NMI}}$  pin until  $V_{CC}$  rises to  $V_{CCTP}$ . As a result, any potential active  $\overline{\text{NMI}}$  will not be initiated until  $V_{CC}$  reaches  $V_{CCTP}$ .

Removal of an active low level on the  $\overline{\text{NMI}}$  pin is controlled by the subsequent rise of the IN pin above  $V_{TP}$ . The initiation and removal of the  $\overline{\text{NMI}}$  signal during power up depends on the relative voltage relationship between  $V_{CC}$  and the IN pin voltage. Note that a fast-slewing power supply may cause the  $\overline{\text{NMI}}$  to be virtually nonexistent on power-up. This is of no consequence, however, since an RST will be active. The  $\overline{\text{NMI}}$  voltage will follow  $V_{CC}$  down until  $V_{CC}$  decays to  $V_{BAT}$ . Once  $V_{CC}$  decays to  $V_{BAT}$ , the  $\overline{\text{NMI}}$  pin will enter a tri-state mode.

## ST INPUT TIMING Figure 2

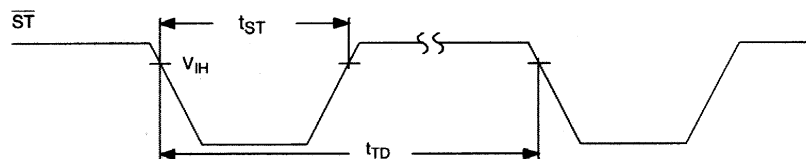

**OSCILLATOR CONTROLS Table 1**

	OSCIN	OSCSEL	Watchdog Timeout Period (typ)		Reset Active Duration
			First Period Following a Reset	Other Timeout	
External	Ext Clk	Low	20480 Clks	5120 Clocks	641 Clks
	Ext Cap	Low	$\cong \frac{2.2 \text{ sec}}{47 \text{ pf}} \times \text{Cpf}$	$\cong \frac{550 \text{ ms}}{47 \text{ pf}} \times \text{Cpf}$	$\cong \frac{69 \text{ ms}}{47 \text{ pf}} \times \text{Cpf}$
Internal	Low	Hi/Open	2.7 sec	170 ms	85 ms
	Hi/Open	Hi/Open	2.7 sec	2.7 sec	85 ms

Note that the OSCIN and OSCSEL pins are tri-stated when  $V_{CC}$  is below  $V_{BAT}$ .

**POWER MONITOR, WATCHDOG TIMER, AND PUSHBUTTON RESET Figure 3**

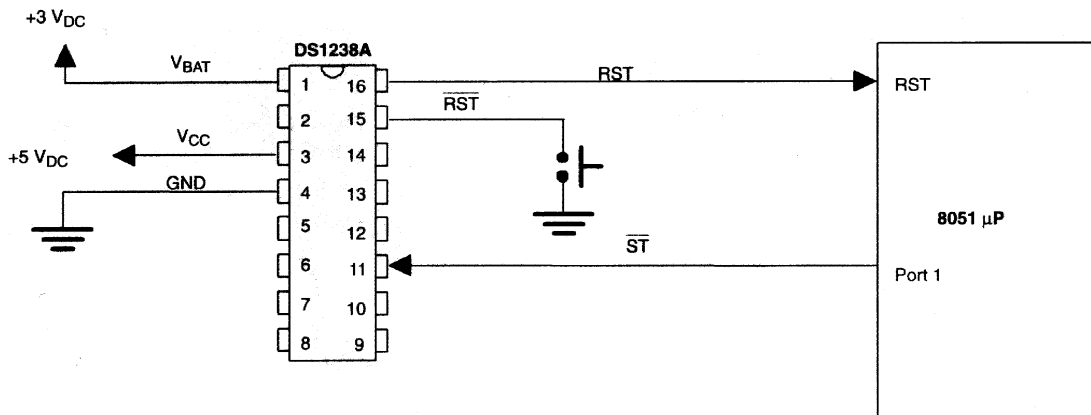

**PUSHBUTTON RESET TIMING Figure 4**

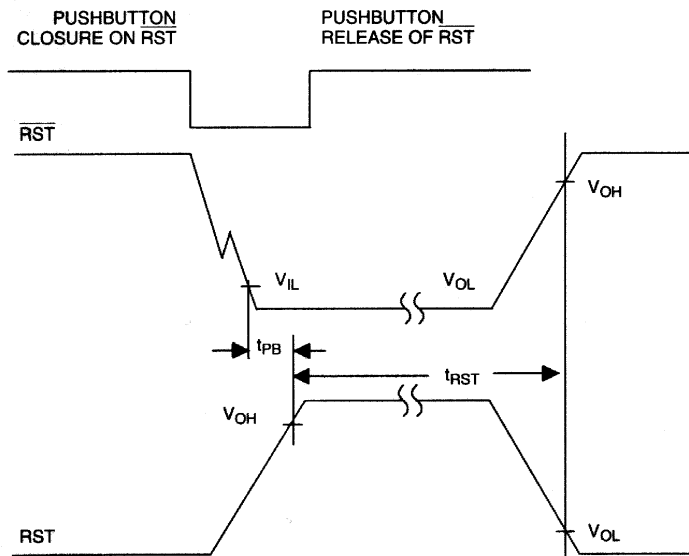

# NON-MASKABLE INTERRUPT Figure 5

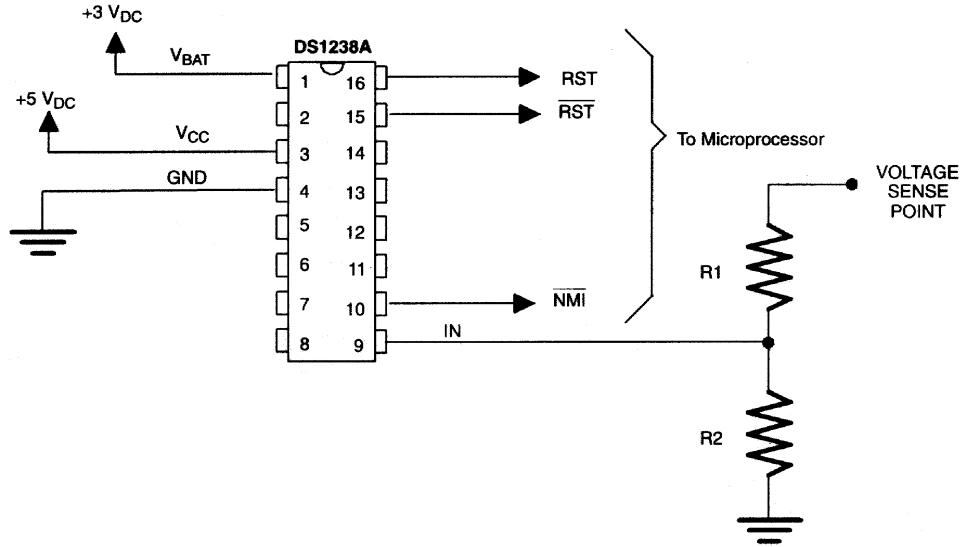

$$V_{\text{SENSE}} = \frac{R1+R2}{R2} \times 1.27$$

$$\text{MAXVOLTAGE} = \frac{V_{\text{SENSE}}}{1.27} \times 5.0 = \text{VMAX}$$

Example 1: 5-Volt Supply, R2 = 10k Ohms,  
 $V_{\text{SENSE}} = 4.8$  Volts

$$4.8 = \frac{R1+10k}{10k} \times 1.27 \geq R1 = 27.8k \text{ Ohm}$$

Example 2: 12-Volt Supply, R2 = 10k Ohms,  
 $V_{\text{SENSE}} = 9.0$  Volts

$$9.0 = \frac{R1+10k}{10k} \times 1.27 \geq R1 = 60.9k \text{ Ohm}$$

$$V_{\text{MAX}} = \frac{9.00}{1.27} \times 5.0 = 35.4 \text{ Volts}$$

# NMI FROM IN INPUT Figure 6

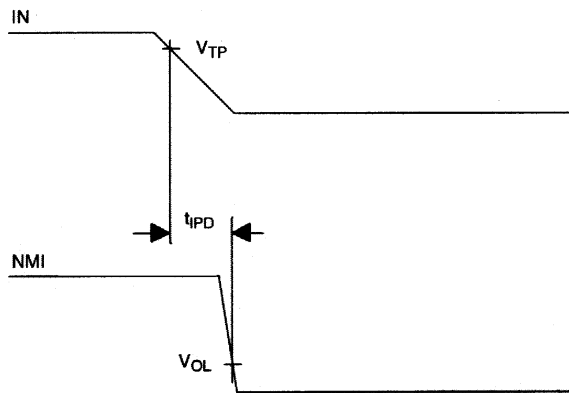

## MEMORY BACKUP

The DS1238A provides all of the necessary functions required to battery back a static RAM. First, an internal switch is provided to supply SRAM power from the primary 5-volt supply ( $V_{CC}$ ) or from an external battery ( $V_{BAT}$ ), whichever is greater. Second, the same power-fail detection described in the power monitor section is used to hold the chip enable output ( $\overline{CEO}$ ) to within 0.3 volts of  $V_{CC}$  or to within 0.7 volts of  $V_{BAT}$ . The output voltage diode drop from  $V_{BAT}$  (0.7V) is necessary to prevent charging of the battery in violation of UL standards. Write protection occurs as  $V_{CC}$  falls below  $V_{CCTP}$  as specified. If  $\overline{CEI}$  is low at the time power-fail detection occurs,  $\overline{CEO}$  is held in its present state until  $\overline{CEI}$  is returned high, or the period  $t_{CE}$  expires. This delay of write protection until the current memory cycle is completed prevents the corruption of data. If  $\overline{CEO}$  is in an inactive state at the time of  $V_{CC}$  fail detection,  $\overline{CEO}$  will be unconditionally disabled within  $t_{CF}$ . During nominal supply conditions  $\overline{CEO}$  will follow  $\overline{CEI}$  with a maximum propagation delay of 20 ns. NO TAG shows a typical nonvolatile SRAM application.

## FRESHNESS SEAL

In order to conserve battery capacity during initial construction of an end system, the DS1238A provides a freshness seal that electrically disconnects the battery. This means that upon battery attachment, the  $V_{CCO}$  output will remain inactive until  $V_{CC}$  is applied. This prevents  $V_{CCO}$  from powering other devices when the battery is first attached, and  $V_{CC}$  is not present. Once  $V_{CC}$  is applied, the freshness seal is broken and cannot be invoked again without subsequent removal and reattachment of the battery.

## POWER SWITCHING

When larger operating currents are required in a battery-backed system, the internal switching devices of the DS1238A may be too small to support the required load through  $V_{CCO}$  with a reasonable voltage drop. For these applications, the PF output is provided to gate external power switching devices. As shown in Figure 8, power to the load is switched from  $V_{CC}$  to battery on power-down, and from battery to  $V_{CC}$  on power-up. The DS1336 is designed to use the PF output to switch between  $V_{BAT}$  and  $V_{CC}$ . It provides better leakage and switchover performance than currently available discrete components. The transition threshold for PF is set to the external battery voltage  $V_{BAT}$ , allowing a smooth transition between sources. Any load applied to the PF pin by an external switch will be supplied by the battery. Therefore, if a discrete switch is used, this load should be taken into consideration when sizing the battery.

## NONVOLATILE SRAM Figure 7

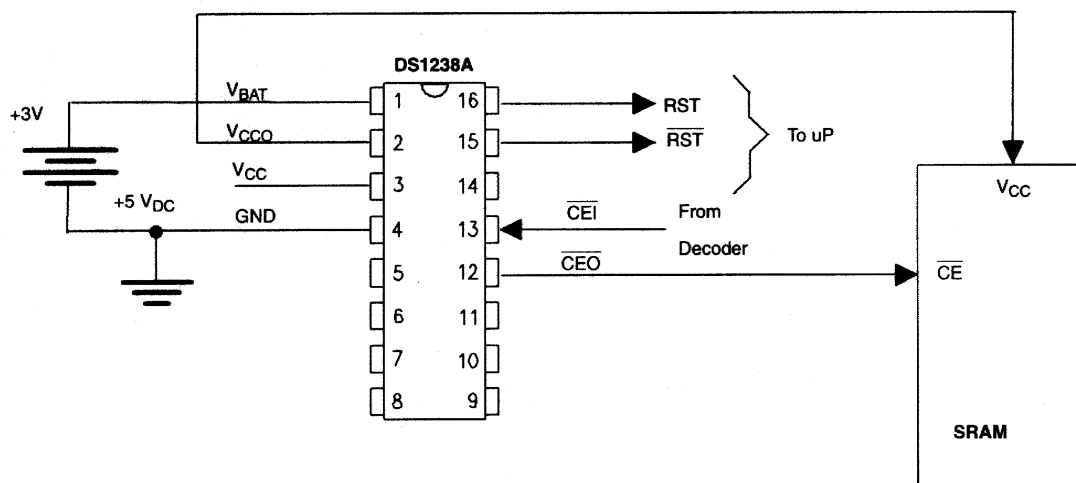

## POWER SWITCHING Figure 8

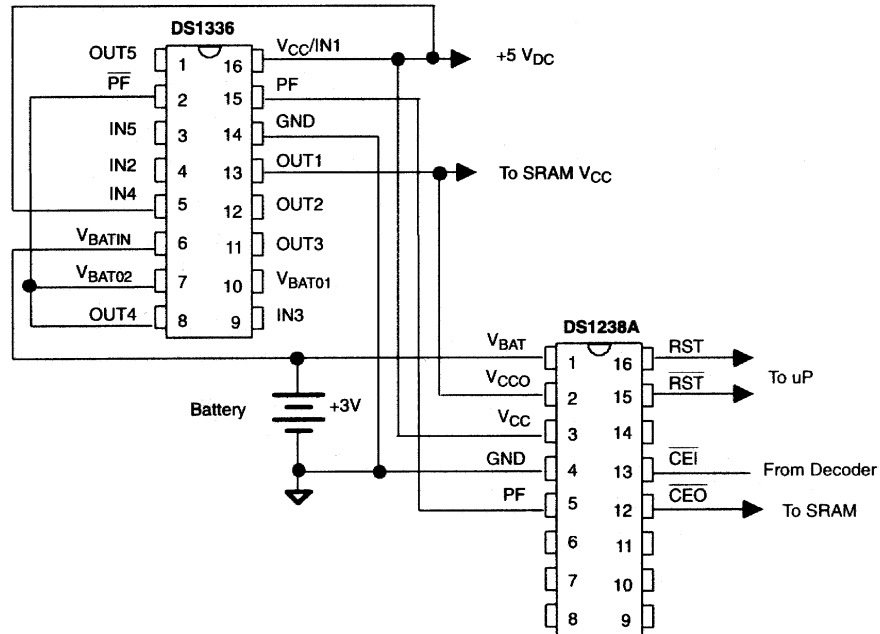

Note: If freshness on the DS1238A is not used,  $\overline{\text{PF}}$  on the DS1336 may be tied to OUT1. This will free IN4, OUT4, and  $V_{\text{BAT01}}$  for system use.

## TIMING DIAGRAMS

This section provides a description of the timing diagrams shown in Figure 9 and Figure 10. Figure 9 illustrates the relationship for power down. As  $V_{\text{CC}}$  falls, the IN pin voltage drops below  $V_{\text{TP}}$ . As a result, the processor is notified of an impending power failure via an active  $\overline{\text{NMI}}$ . This gives the processor time to save critical data in nonvolatile SRAM. As the power falls further,  $V_{\text{CC}}$  crosses  $V_{\text{CCTP}}$ , the power monitor trip point. When  $V_{\text{CC}}$  reaches  $V_{\text{CCTP}}$ , and active RST and  $\overline{\text{RST}}$  are given. At this time,  $\overline{\text{CEO}}$  is brought high to write-protect the RAM. When the  $V_{\text{CC}}$  reaches  $V_{\text{BAT}}$ , a power-fail is issued via the PF pin.

Figure 10 shows the power-up sequence. As  $V_{\text{CC}}$  slews above  $V_{\text{BAT}}$ , the PF pin is deactivated. An active reset occurs as well as an  $\overline{\text{NMI}}$ . Although the  $\overline{\text{NMI}}$  may be short due to slew rates, reset will be maintained for the standard  $t_{\text{RPU}}$  timeout period. At a later time, if the IN pin falls below  $V_{\text{TP}}$ , a new  $\overline{\text{NMI}}$  will occur. If the processor does not issue an  $\overline{\text{ST}}$ , a watchdog reset will also occur. The second  $\overline{\text{NMI}}$  and RST are provided to illustrate these possibilities.



**POWER-DOWN TIMING Figure 9**

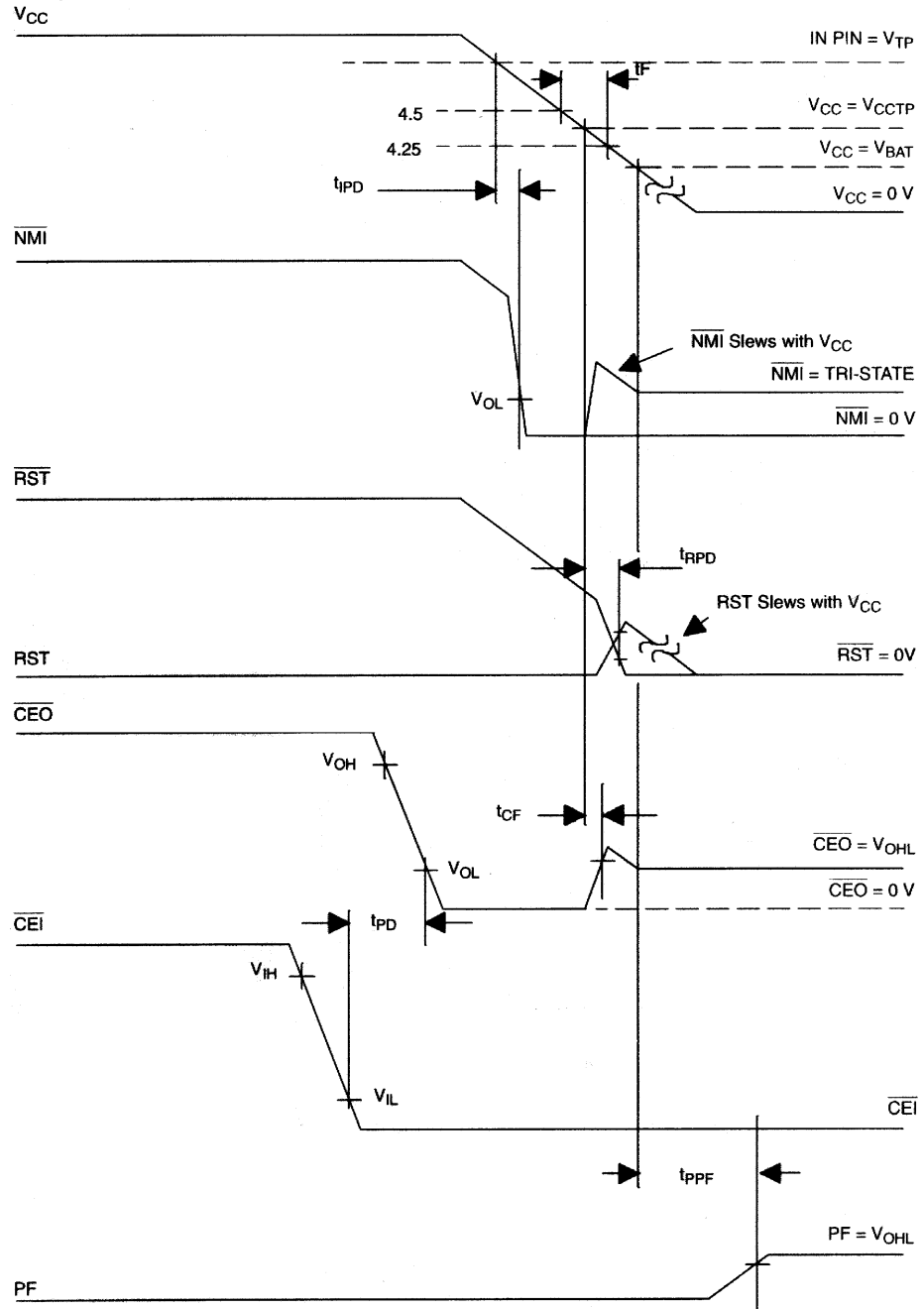

## POWER-UP TIMING Figure 10

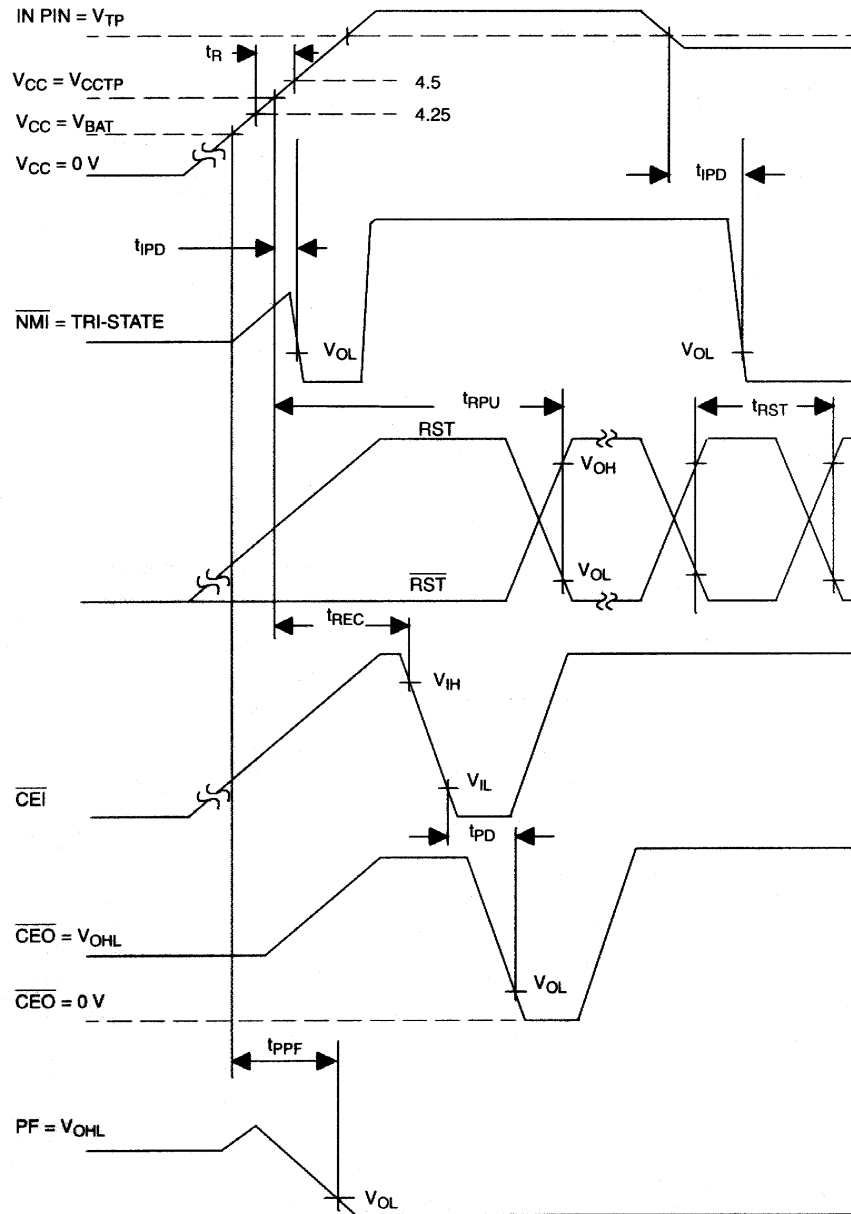

**ABSOLUTE MAXIMUM RATINGS\***

Voltage on V <sub>CC</sub> Pin Relative to Ground	-0.5V to +7.0V
Voltage on I/O Relative to Ground	-0.5V to V <sub>CC</sub> + 0.5V
Operating Temperature	0°C to 70°C
Operating Temperature (Industrial Version)	-40°C to +85°C
Storage Temperature	-55°C to +125°C
Soldering Temperature	260°C for 10 seconds

\* This is a stress rating only and functional operation of the device at these or any other conditions above those indicated in the operation sections of this specification is not implied. Exposure to absolute maximum rating conditions for extended periods of time may affect reliability.

**RECOMMENDED DC OPERATING CONDITIONS**

(0°C to 70°C)

PARAMETER	SYMBOL	MIN	TYP	MAX	UNITS	NOTES
Supply Voltage	V <sub>CC</sub>	4.5	5.0	5.5	V	1
Supply Voltage (5% Option)	V <sub>CC</sub>	4.75	5.0	5.5	V	1
Input High Level	V <sub>IH</sub>	2.0		V <sub>CC</sub> +0.3	V	1
Input Low Level	V <sub>IL</sub>	-0.3		+0.8	V	1
IN Input Pin	V <sub>IN</sub>	0		V <sub>CC</sub>	V	1
Battery Input	V <sub>BAT</sub>	0		4.0	V	1

**DC ELECTRICAL CHARACTERISTICS**(0°C to 70°C; V<sub>DD</sub>= 5V ± 10%)

PARAMETER	SYMBOL	MIN	TYP	MAX	UNITS	NOTES
Supply Current	I <sub>CC</sub>			4	mA	2
Battery Current	I <sub>BAT</sub>	0		200	nA	2, 12
Supply Output Current (V <sub>CCO</sub> = V <sub>CC</sub> - 0.3V)	I <sub>CCO1</sub>			100	mA	3
Supply Out Current (V <sub>CC</sub> < V <sub>BAT</sub> )	I <sub>CCO2</sub>			1	mA	4
Supply Output Voltage	V <sub>CCO</sub>	V <sub>CC</sub> -0.3			V	1
Battery Back Voltage	V <sub>CCO</sub>		V <sub>BAT</sub> -0.8		V	6
Low Level @ RST	V <sub>OL</sub>			0.4	V	1
Output Voltage @ -500 μA	V <sub>OH</sub>	V <sub>CC</sub> -0.5V	V <sub>CC</sub> -0.1V		V	1
$\overline{\text{CEO}}$ and PF Output	V <sub>OHL</sub>		V <sub>BAT</sub> -0.8		V	6
Input Leakage Current	I <sub>LI</sub>	-1.0		+1.0	μA	2
Output Leakage Current	I <sub>LO</sub>	-1.0		+1.0	μA	11
Output Current @ 0.4V	I <sub>OL</sub>			4.0	mA	9
Output Current @ 2.4V	I <sub>OH</sub>	-1.0			mA	10
Power Sup. Trip Point	V <sub>CCTP</sub>	4.25	4.37	4.50	V	1
Power Supply Trip (5% Option)	V <sub>CCTP</sub>	4.50	4.62	4.75	V	
IN Input Pin Current	I <sub>CCIN</sub>	-1.0		+1.0	μA	
IN Input Trip Point	V <sub>TP</sub>	1.15	1.27	1.35	V	1

**AC ELECTRICAL CHARACTERISTICS**(0°C to 70°C;  $V_{CC} = 5V \pm 10\%$ )

PARAMETER	SYMBOL	MIN	TYP	MAX	UNITS	NOTES
$V_{CC}$ Fail Detect to RST, $\overline{RST}$	$t_{RPD}$	40	100	175	$\mu s$	
$V_{TP}$ to $\overline{NMI}$	$t_{IPD}$	40	100	175	$\mu s$	
RESET Active OSCSEL=high	$t_{RST}$	40	85	150	ms	
$\overline{ST}$ Pulse Width	$t_{ST}$	20			ns	13
PBRST @ $V_{IL}$	$t_{PB}$	30			ms	
$V_{CC}$ Slew Rate 4.75 to 4.25	$t_F$	300			$\mu s$	
Chip Enable Prop Delay	$t_{PD}$			20	ns	
$V_{CC}$ Fail to Chip Enable High	$t_{CF}$	7	12	144	$\mu s$	11
$V_{CC}$ Valid to RST (RC=1)	$t_{FPU}$			100	ns	
$V_{CC}$ Valid to RST	$t_{RPU}$	40	100	150	ms	5
$V_{CC}$ Slew to 4.25 to $V_{BAT}$	$t_{FB1}$	10			$\mu s$	
Chip Enable Output Recovery Time	$t_{REC}$	0.1			$\mu s$	7
$V_{CC}$ Slew 4.25 to 4.75	$t_R$	0			$\mu s$	
Chip Enable Pulse Width	$t_{CE}$			5	$\mu s$	8
Watchdog Time Delay Int Clock Long period	$t_{TD}$	1.7	2.7		s	
Short period		110	170		ms	
Watchdog Time Delay, Ext Clock, after Reset	$t_{TD}$		20480		clocks	
Normal			5120		clocks	
$V_{BAT}$ Detect to PF	$t_{PPF}$			2	$\mu s$	
OSC IN Frequency	$f_{OSC}$	0		250	kHz	

**CAPACITANCE** $(t_A = 25^\circ C)$ 

PARAMETER	SYMBOL	MIN	TYP	MAX	UNITS	NOTES
Input Capacitance	$C_{IN}$			5	pF	
Output Capacitance	$C_{OUT}$			7	pF	

**NOTES:**

1. All voltages referenced to ground.
2. Measured with  $V_{CC0}$ ,  $\overline{CEO}$ , PF,  $\overline{ST}$ ,  $\overline{RST}$ ,  $\overline{RST}$ , and  $\overline{NMI}$  pin open.
3.  $I_{CC01}$  is the maximum average load which the DS1238A can supply at  $V_{CC}=3V$  through the  $V_{CC0}$  pin during normal 5-volt operation.
4.  $I_{CC02}$  is the maximum average load which the DS1238A can supply through the  $V_{CC0}$  pin during data retention battery supply operation, with a maximum drop of 0.8 volts for commercial, 1.0V for industrial.
5. With  $t_R = 5 \mu s$ .
6.  $V_{CC0}$  is approximately  $V_{BAT}-0.5V$  at  $1 \mu A$  load.
7.  $t_{REC}$  is the minimum time required before  $\overline{CEI}/\overline{CEO}$  memory access is allowed.
8.  $t_{CE}$  maximum must be met to insure data integrity on power loss.
9. All outputs except  $\overline{RST}$  which is  $25 \mu A$  max.
10. All outputs except  $\overline{RST}$ ,  $\overline{RTV}$ , and  $\overline{NMI}$  which is  $25 \mu A$  min.
11. The  $\overline{ST}$  pin will sink  $\pm 50 \mu A$  in normal operation. The OSCIN pin will sink  $\pm 5 \mu A$  in normal operation. The OSCSEL pin will sink  $\pm 10 \mu A$  in normal operation.
12.  $I_{BAT}$  is measured with  $V_{BAT}=3.0V$ .
13.  $\overline{ST}$  should be active low before the watchdog is disabled (i.e., before the  $\overline{ST}$  input is tristated).

